



Specification:  
 Current Rating: 2.0A;  
 Current Voltage: 12V;  
 Withstand Voltage: 500V;  
 Contact Resistance: 30mΩ MAX  
 Insulation: Resistance: 500MΩ;  
 Working Temperature: -40℃~+85℃;  
 Housing Material: LCP  
 Contact Material: Phosphor Brass,  
 Contact Area plated: Au  
 Life Time: Over 3000times;

PART NO.	DIM A	DIM B	DIM C
SLBM83-3802G1LP1952	9.0	5.0	2.5
SLBM83-3803G1LP1952	11.5	7.5	5.0
SLBM83-3804G1LP1952	14.0	10.0	7.5
SLBM83-3805G1LP1952	16.5	12.5	10.0

### Ordering Information

SLBM83-38 XX XX L X 195 2

Insulator Height	No. of Pins	Contact Plating	Pressed method	Spring Height
1.7=17	02-08	G0=Gold Flash	P=Positive press ↓	1.4=140
2.6=26		G1=3u"Gold	S=Side press →	1.0=100
3.8=38		G2=5u"Gold		2.2=220
		G3=10u"Gold		
		G4=15u"Gold		
		G5=30u"Gold		

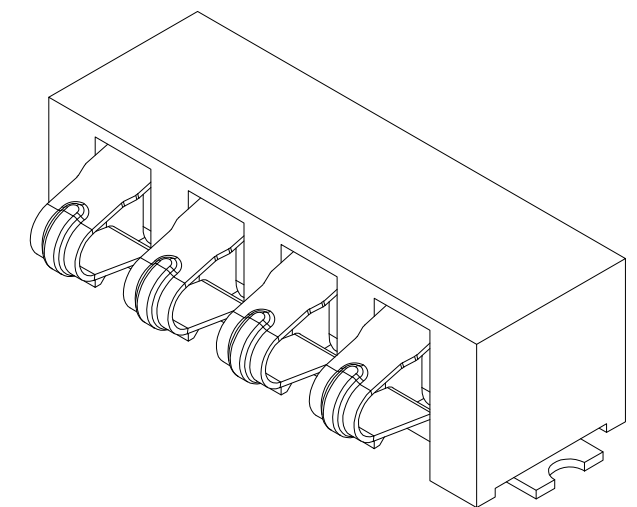
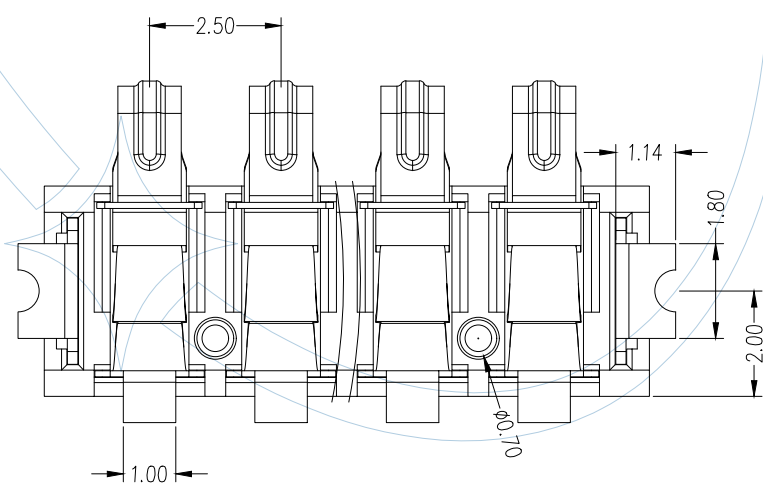
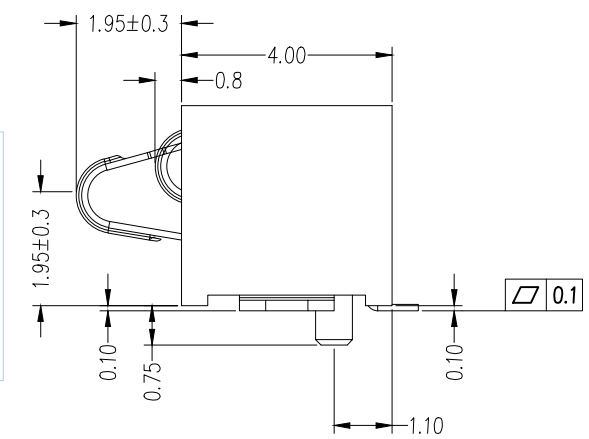
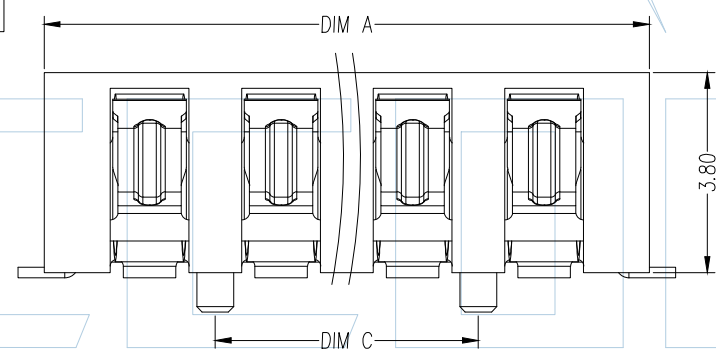
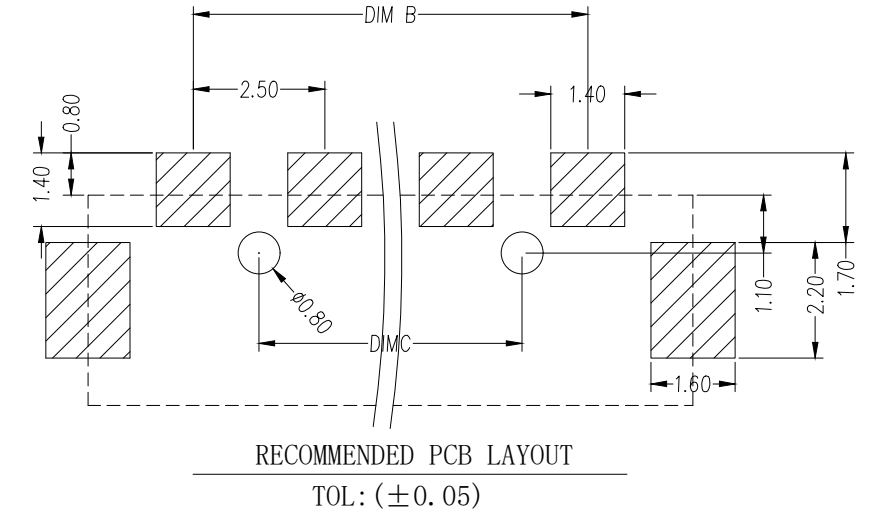
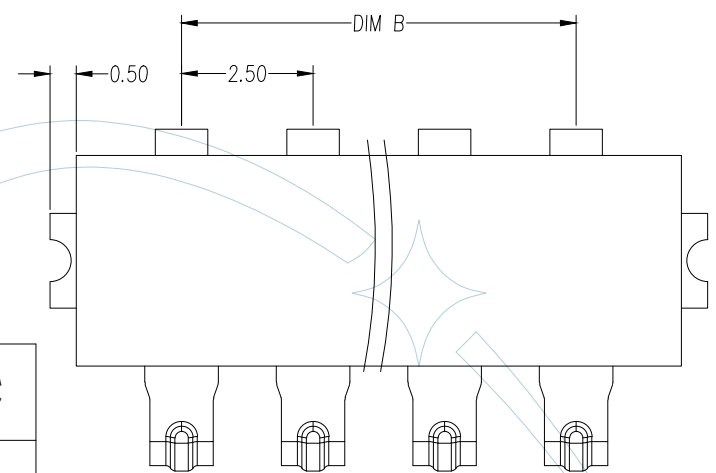

ITEM	Pitch	Mating
Standard	2.5	SLBF
Alternate		

REV	DATE	MODIFICATION DESCRIPTION	CHANGE	APPROVE	ENGINEERING		DRAW	SCALE	FREE
					DIM	TOL			
					X.X	±0.40		UNIT	mm
					X.XX	±0.25		SIZE	A3
					X.XXX	±0.15		SHEET	1/1
					Angle	± 3°		PROJ.	☒ ☒

PART NO.  
SLBM83-3802G1LP1952  
 TITLE:  
2.5mm弹片电池座 H=3.8  
弹高1.95 侧压 带柱  
 Customer NO.

**YLCCON**  
 Dongguan YILI Electronic Technology Co., Ltd  
 Tel:  
 FAX:  
 E-mail:  
[http:// www.ylconn.cn](http://www.ylconn.cn)