

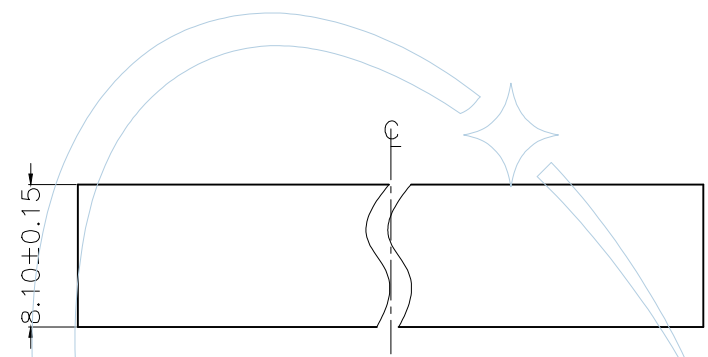

NOTES:
 Current Rating:.1.0AMP
 Withstand Voltage:1000V AC/DC
 Contact Resistance:20mΩ Max
 Insulation Resistance:1000MΩ Min
 Operation Temperature:-40℃ to +105℃

Contact Material:Phosphor Bronze or Brass
 Contact Plating:Au or Sn over Ni
 Insulator Material:PA6T/PA9T/LCP+30%G.F (UL94V-0)

Recommended P.C.B Layout(TOP Side)
 (PCB BOARD TOLERANCE±0.05)

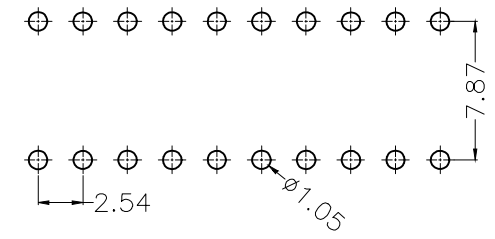

Ordering Information

FHB159-2 XX R XX 6UN X X

No. of Pins
02-40

Contact Plating:
 G0=Gold Flash
 G1=3u"Gold
 G2=5u"Gold
 G3=10u"Gold
 G4=15u"Gold
 G5=30u"Gold
 S0=Gold Flash/Tin
 S1=3u"Gold/Tin
 S2=5u"Gold/Tin
 S3=10u"Gold/Tin
 S4=15u"Gold/Tin
 S5=30u"Gold/Tin
 SW=Tin

6=PA6T
 9=PA9T

Packing
 T=Tube

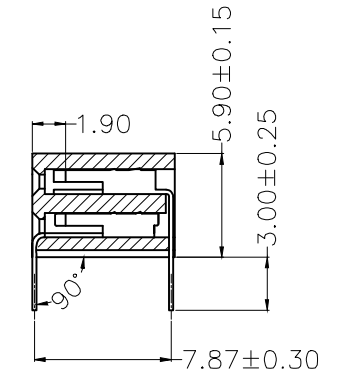
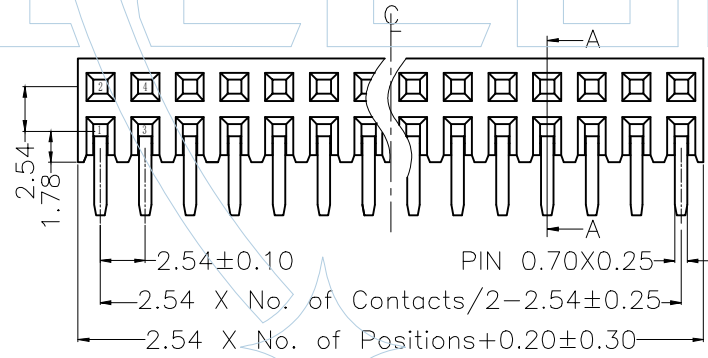

SECTION: A-A

ITEM	Pitch	Mating
Standard	2.54	PHA125/PHA120/PHA115
Alternate		

REV	DATE	MODIFICATION DESCRIPTION	CHANGE	APPROVE
1				
2				
3				
4				

ENGINEERING		DRAW
X.X	±0.40	
X.XX	±0.25	
X.XXX	±0.15	
Angle	± 3°	
DIM	TOL	APPROVE

SCALE	FREE
UNIT	mm
SIZE	A3
SHEET	1/1
PROJ.	☐ ⊗

PART NO. FHB159-2XXMX6UNXX
TITLE: 2.54mm排母 双排90° 侧 插距=5.9
Customer NO.

YLCCON
 Dongguan YILI Electronic Technology Co., Ltd
 Tel:
 FAX:
 E-mail:
[http:// www.ylccon.cn](http://www.ylccon.cn)