



NOTES:
Current Rating: .1.0AMP
Withstand Voltage:1000V AC/DC
Contact Resistance:20mΩ Max
Insulation Resistance:1000MΩ Min
Operation Temperature:-40 to +105

Contact Material:Phosphor Bronze or Brass
Contact Plating:Au or Sn over Ni
Insulator Material:PA6T/PA9T/LCP+30%G.F (UL94V-0)

Ordering Information

EJC230-XX R XX B X X 1

No. of Pins	Contact Plating:	Color	Packing
08 30	G0=Gold Flash	B=Black	A=Tray
10 34	G1=3u"Gold		T=Tube
14 40	G2=5u"Gold		
16 44	G3=10u"Gold		
20 50	G4=15u"Gold		
24 60	G5=30u"Gold		
26 64	S0=Gold Flash/Tin		
	S1=3u"Gold/Tin		
	S2=5u"Gold/Tin		
	S3=10u"Gold/Tin		
	S4=15u"Gold/Tin		
	S5=30u"Gold/Tin		
	SN=Tin		

Recommended P.C.B Layout(Top Side)
(PCB BOARD TOLERANCE±0.05)

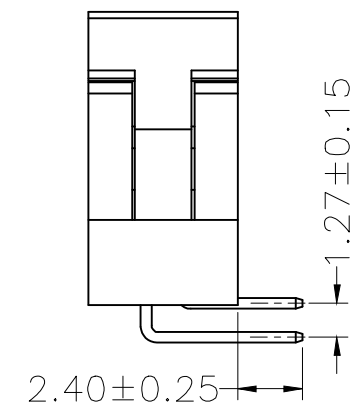
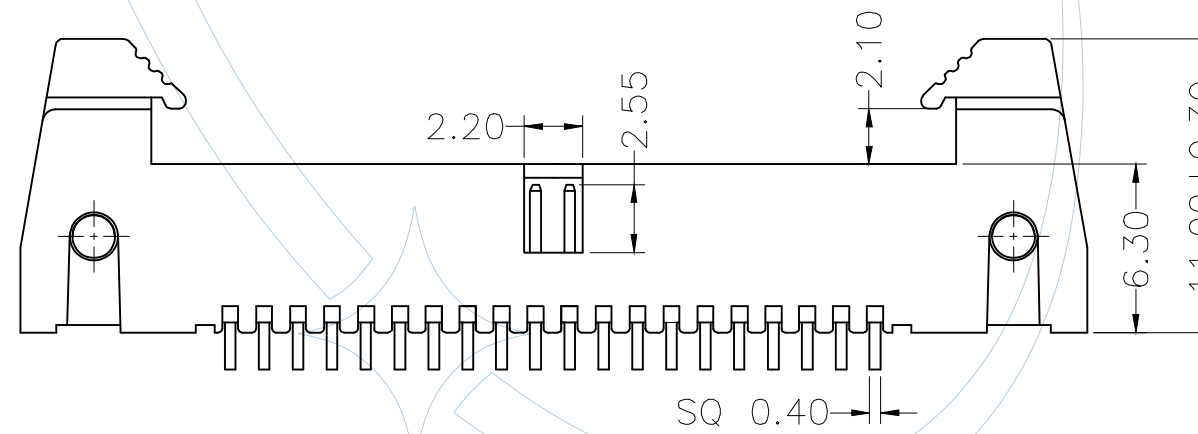
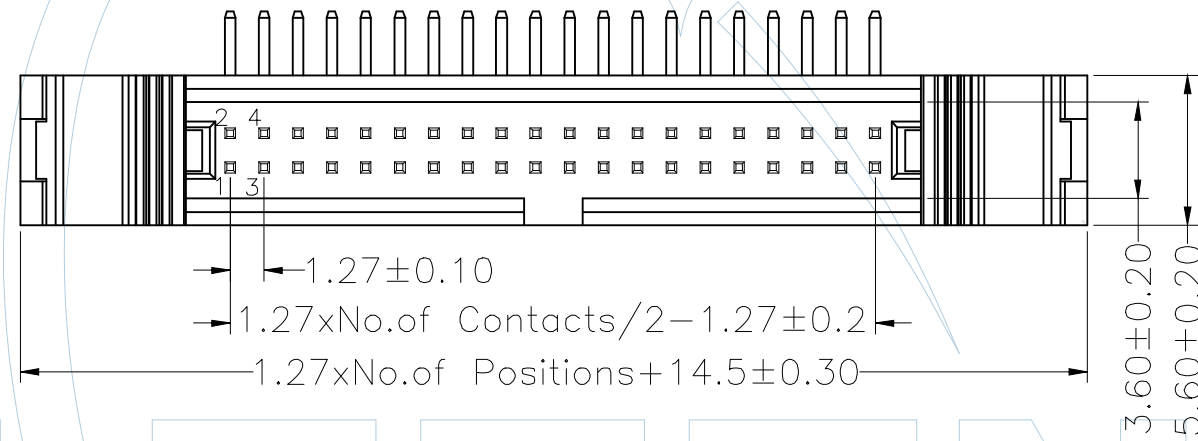
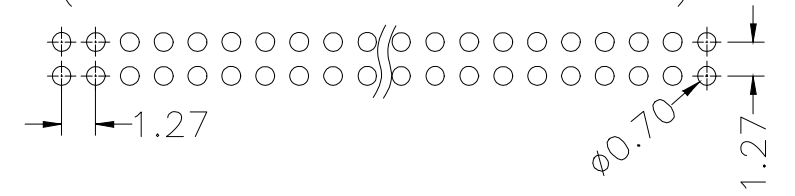

ITEM	Pitch	Mating
Standard	1.27	IDCE232
Alternate		

				ENGINEERING		DRAW		SCALE		FREE		PART NO.	
				X.X ±0.40		DESIGN		UNIT		mm		EJC230-XXXXBXX1	
				X.XX ±0.25		CHECK		SIZE		A3		TITLE:	
				X.XXX ±0.15		APPROVE		SHEET		1/1		1.27mm 牛角 90°	
				Angle ± 3°				PROJ.		⊕ ⊗		Customer NO.	
REV	DATE	MODIFICATION DESCRIPTION		CHANGE	APPROVE	DIM	TOL						

YLCCON
Dongguan YILI Electronic Technology Co., Ltd

Tel:
FAX:
E-mail:
[http:// www.ylcon.cn](http://www.ylcon.cn)

