

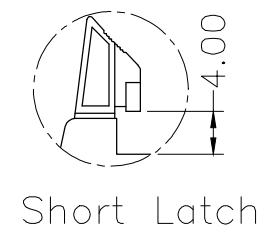

NOTES:
 Current Rating: 3.0AMP
 Withstand Voltage: 1000V AC/DC
 Contact Resistance: 20mΩ Max
 Insulation Resistance: 1000MΩ Min
 Operation Temperature: -40°C to +105°C

Contact Material: Phosphor Bronze or Brass
 Contact Plating: Au or Sn over Ni
 Insulator Material: PA6T/PA9T/LCP+30%G.F (UL94V-0)

Recommended P.C.B Layout (Top Side)
 (PCB BOARD TOLERANCE ±0.05)

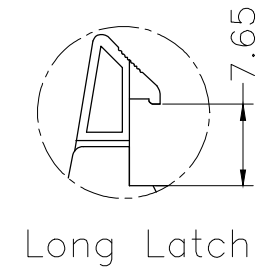
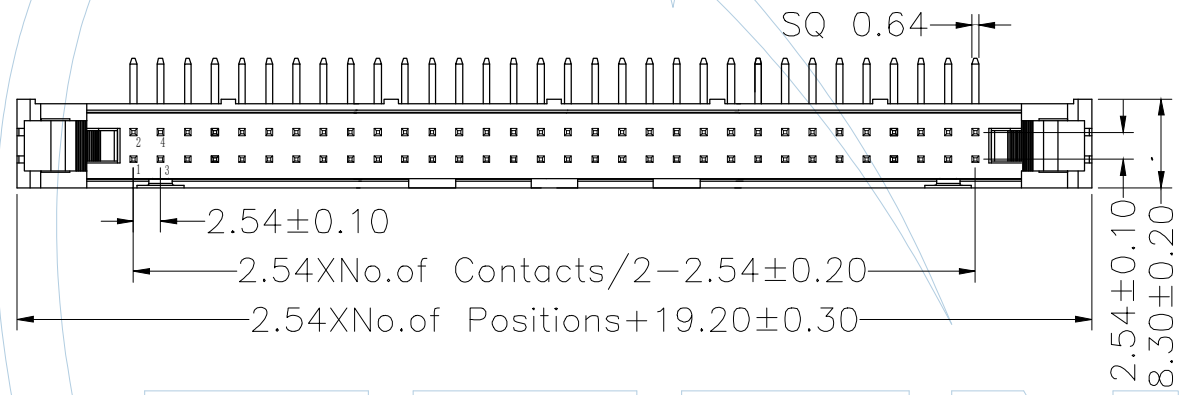
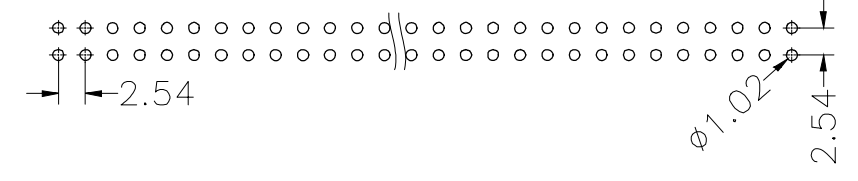

Ordering Information

EJC210-XX R XX B X X 1

No. of Pins
 08 30
 10 34
 14 40
 16 44
 20 50
 24 60
 26 64

Contact Plating:
 G0=Gold Flash
 G1=3u"Gold
 G2=5u"Gold
 G3=10u"Gold
 G4=15u"Gold
 G5=30u"Gold
 S0=Gold Flash/Tin
 S1=3u"Gold/Tin
 S2=5u"Gold/Tin
 S3=10u"Gold/Tin
 S4=15u"Gold/Tin
 S5=30u"Gold/Tin
 SN=Tin

Color
 B=Black
 U=Blue
 E=Gray (413C)
 G=Gray (427C)

Packing
 A=Tray
 T=Tube

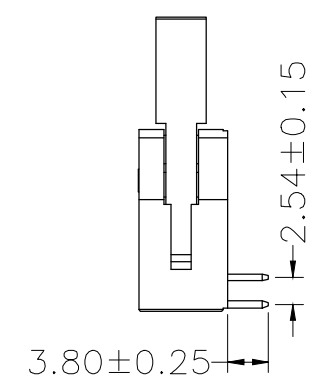
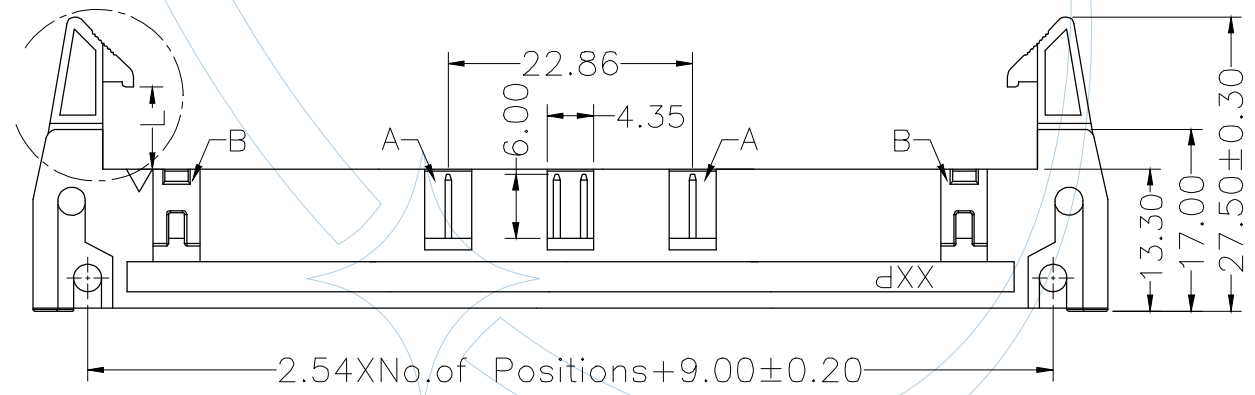

ITEM	Pitch	Mating
Standard	2.54	IDCE211/E212
Alternate		

REV	DATE	MODIFICATION DESCRIPTION	CHANGE	APPROVE	ENGINEERING		DRAW	SCALE	FREE	PART NO. EJC210-XXRXXBXX1
					DIM	TOL				
					X.X	±0.40	DESIGN			TITLE: 2.54mm 铁钩牛角 90°
					X.XX	±0.25	CHECK			
					X.XXX	±0.15	APPROVE			Customer NO.
					Angle	± 3°				
								PROJ.	☒ ☒	

YLCCON
 Dongguan YILI Electronic Technology Co., Ltd
 Tel:
 FAX:
 E-mail:
[http:// www.ylcon.cn](http://www.ylcon.cn)