

HF



RoHS

Specification:
 Current Rating: 2.0A;
 Current Voltage: 12V;
 Withstand Voltage: 500V;
 Contact Resistance: 30mΩ MAX
 Insulation: Resistance: 500MΩ;
 Working Temperature: -40℃~+85℃;
 Housing Material: LCP
 Contact Material: Phosphor Brass,
 Contact Area plated Au 3u"
 Life Time: Over 3000times;

PART NO.	DIM A	DIM B	DIM C
SLBM82-2602G1LP1901	4.0	2.0	
SLBM82-2603G1LP1901	6.0	4.0	2.0
SLBM82-2604G1LP1901	8.0	6.0	4.0
SLBM82-2605G1LP1901	10.0	8.0	6.0
SLBM82-2606G1LP1901	12.0	10.0	8.0
SLBM82-2607G1LP1901	14.0	12.0	10.0
SLBM82-2608G1LP1901	16.0	14.0	12.0

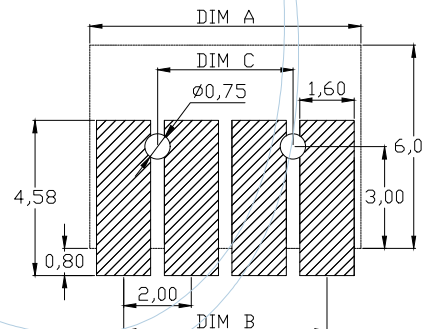
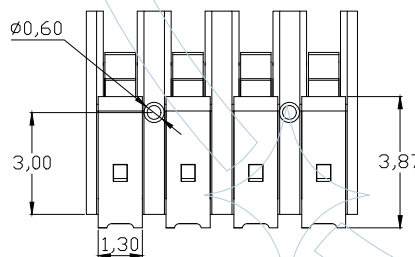
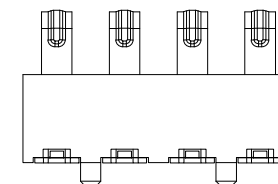
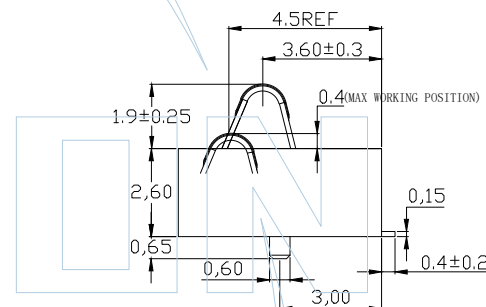
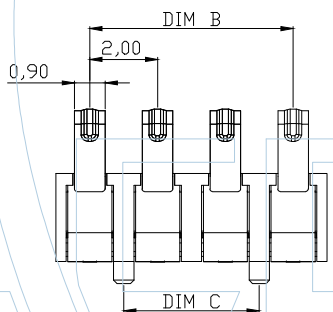
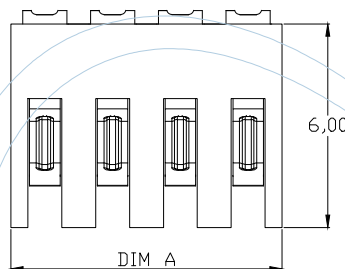

RECOMMENDED PCB LAYOUT
 TOL:(±0.05)

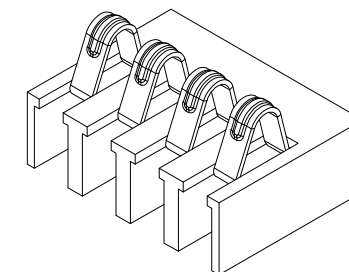

Ordering Information

SLBM82-26 XX XX L X XXX 1

Insulator Height 2.6=26
 No. of Pins 02-08
 Contact Plating
 G0=Gold Flash
 G1=3u"Gold
 G2=5u"Gold
 G3=10u"Gold
 G4=15u"Gold
 G5=30u"Gold
 Pressed method
 P=Positive press ↓
 Spring Height
 1.4=140
 1.0=100
 2.2=220

ITEM	Pitch	Mating
Standard	2.0	SLBF82
Alternate		

REV	DATE	MODIFICATION DESCRIPTION	CHANGE	APPROVE	ENGINEERING		DRAW	SCALE	FREE	PART NO.
					X.X	±0.40				
					X.XX	±0.25	DESIGN	UNIT	mm	SLBM82-2602G1LP1901
					X.XXX	±0.15	CHECK	SIZE	A3	TITLE: 2.0mm弹片电池座
					Angle	± 3°	APPROVE	SHEET	1/1	H=2.6 弹高1.9 正压
					DIM	TOL		PROJ.	☒	Customer NO.

YLCCON

Dongguan YILI Electronic Technology Co., Ltd

Tel:
 FAX:
 E-mail:
[http:// www.ylconn.cn](http://www.ylconn.cn)